



TRIAL APPLICATION OF THE FORMAL FIRE RISK ASSESSMENT TO FIRE PREVENTION IN SHIP ENGINE ROOMS

Adam Charchalis, Stefan Czyż

*Gdynia Maritime University, Faculty of Marine Engineering
Morska Street 83, 81-225 Gdynia, Poland
e-mail: achar@am.gdynia.pl; zpozar@am.gdynia.pl*

Abstract

This paper contains an interpretation of the measures to prevent fire in ship engine rooms, which have been developed by the International Marine Organization as the Guidelines MSC.1/Circ 1321. Attention is drawn to the risk control measures in the design, construction, testing, installation and inspection of systems containing flammable oils.

The measures to prevent fire in flammable oils were verified using theoretical technique i.e. the formal fire risk assessment (FFRA). The FFRA is based on the probabilistic model for fire frequency calculations. The model has been described and results of trial application of the FFRA has been presented.

It can be said the effectiveness of risk control measures can be examined quantitatively by applying the analytical technique. However, making generic model for detailed examination with adequate accuracy poses number of challenges, the most significant being lack of adequate statistic data on past fire accidents and consideration of the human factor.

1. Introduction

Statistics on world fleet fire safety show that the engine room fire hazard in ships expressed in terms of relative frequency amounts about 1/1000 ship years, which is 30-50% of the overall ship fire accident rate [1]. The most likely cause of an engine room fire is the leakage or spray flammable oil. The past data on fires shows that fire due to leakage and dispersion of fuel oil, lubricating oil and waste oil account for about 60% of all engine room fires [6].

In responding to the needs for an improvement of the fire safety record in engine-rooms, the IMO developed the Guidelines for Measures to Prevent Fires in Engine-Rooms and Cargo Pump Rooms. Guidelines related to flammable oil fires were verified using an analytic technique named Formal Fire Risk Assessment (FFRA).

2. Interpretation of the guidelines for measures to prevent fire in engine-rooms

Mostly, the guidelines are aimed at the prevention of fires caused by self ignition of flammable oils. They are oriented towards elimination of malfunctions and leakages in flammable oil systems, insulating hot surfaces and ensuring safe atmosphere in engine-room spaces.

2.1. Elimination of malfunctions and leakages of flammable oil systems

The basic requirement enabling elimination of leakages of flammable oil systems is to

ensure tightness of pipelines under pressure pulsations generated by injection pumps. Contractors of systems are obliged to inform users about maximum (peak) values of pressure pulsations, which should not exceed 1.6 MPa at the outlet of injection pump sets.

In order to eliminate pipeline damages (leakages) caused by vibrations, apart from meeting ISO and classification societies' requirements, it is recommended to install pressure vibration dampers in injection pipes, and to use injection pumps ensuring a fixed injection pressure.

Operating practice has shown that currently used mechanical pressure accumulators and gas filled bellows are subject to fatigue damages, and their responsiveness is prolonged [1].

Fuel oil system sets should be selected and assembled in consideration of a possibility for vibrations in injection pipes to appear. It is highly recommended to use flanged joints to ensure a proper preliminary tension of joint bolts.

In order to limit fuel oil and diesel oil dispersion caused by lack of tightness, at pressure exceeding 0.18 N/mm^2 , pipeline joints should be shielded in the vicinity of 'hot surfaces' (it also concerns centrifuge and fuel oil and diesel oil treatment systems). In engine supply systems, jacketed injection pipes with drain space and leakage signaling system are recommended.

In order to prevent leakages in elastic joints and elastic hoses, the following elements are recommended:

- construction approval and pressure test certificates (every 5 years),
- adaptation of constructions for working conditions, i.e. temperature, pressure, mechanical load, properties of liquids, etc.,
- conditions for pipe installation, i.e. maximum length and radiuses of bending, curve angles, direction deviation, supporting structures,
- frequency and verification criteria for elastic hoses subject to replacement.

In tanks with flammable liquids (fuel oil, lubricant oil, heating oil, and hydraulic oil), it is recommended to use equipment preventing excessive pressure and temperature increase, and spill caused by lack of tightness or overflow. Such systems include, inter alia:

systems signaling critical levels,
overflow and ventilation pipes,
systems signaling critical temperature (220°C),

level gauges and testing devices, constructed according to the designs included in "The Guidelines and requirements of classification societies.

In order to ensure tightness of other fuel system elements, such as filters, expansion compensators, measuring instruments, and pipelines fittings, construction approval by supervising institutions, pressure tests certificates, spray shields and drainage of leakages, adaptation for working conditions (vibrations and high temperature), appropriate assembly stresses, etc., are recommended.

For repair and service systems of fuel installations, it is recommended to include the following operations:

- execution of procedures according to 'checklists', especially in case of replacement of parts and assembly,
- coordination of installation (assembly) by responsible person responsible for it' who should ensure full implementation of project goals according to detailed design documentation,
- identification of vibrations, fatigue stresses of welded and hardened joints, and damages of elements, on the basis of recognized diagnostic procedures,
- periodic verification of preliminary tension of injection pipes' joint bolts (every 3 months),
- periodic verification of low pressure pipelines fittings (every 6 months),
- verification of threaded joints during every assembly.

2.2. Hot spots insulation

In accordance with SOLAS Convention, 'hot surfaces' in an engine room (exceeding 220°C) should be thermally isolated. The isolation is approved by a supervising (classifying) institution. In particular, isolation of external surfaces is recommended for outlet exhaust pipes, boiler burners housing and units, turbo compressors exhaust pipes and frames, bare metal friction parts, inert gas generators, incinerating plants and highly loaded electrical control panels.

Apart from isolation, ventilation of the surrounding space is applied as well as water spray systems (Hi-Fog) for such machines as centrifuge boilers, fuel oil and diesel oil boilers, electrical boards and systems (wires).

The temperature in fuel oil and diesel oil tanks placed in the vicinity of boilers should not exceed 10° below the flash point of flammable oil. Boiler control systems should ensure automatic fuel cut-off in case of flame failure, and burner system interlock in case if fuel supply is turned on.

The temperature of electric supply elements and drive transmission elements (glands, bearings) of flammable liquid pumps, should be constantly controlled through permanent electrical systems with sensors responding between 60 – 80° (with automatic pump turn-off).

In steam (electrical) boilers for flammable liquids, temperature and fuel failure control and signaling systems, and automatic supply switches (at 220°C).

In heating oil systems with combustion boilers, protection against an ignition includes temperature sensors in tanks, emergency tank drainage, fire and explosive mixtures detection, water spray systems, pressurized circuits of oil, safety temperature switch and pipe tightness inspections and tests.

It is recommended to conduct hot surfaces identification and isolation checks periodically, with the use of Thermo Vision cameras or laser thermometers with accordance to approved procedures.

2.3. Safe atmosphere

In order to ensure safe atmosphere of engine rooms (as well as inside 'hot machines') it is recommended to apply ventilation systems of capacity sufficient for safe dilution of flammable mixtures of gas and oil mist below 5% of the lower explosive limit (LEL). The atmosphere should be controlled by fixed elements of flammable gas, oil mist and smoke detection systems. Sensors layout should take into consideration the characteristics of space ventilation. Detailed design guidelines in this scope have not been prepared yet because of the lack of data which can be drawn up on the basis of already advanced computer simulations [2].

Recommendations for ventilation and atmosphere control also concern rooms with power hydraulics and heating oil systems, and centrifuges.

3. Formal fire risk assessment

The formal fire risk assessment involves the following steps:

- identification and classification of potential fire sources (liquid leakage and ignition),
- adoption of fire event tree,
- calculations of relative frequencies (probability) of various types of fires.

3.1. Identification and classification of fire sources

Fire sources identification involves selection of definite number of system elements, the damages of which may result in flammable liquid leakage and self-ignition. Such elements as, inter alia, pipelines joints and sections, valves and system equipment, are taken into consideration.

Sources of leakages are regarded as fire sources when they are at a specific (established) distance from the source of ignition, such as exhaust pipes, boilers, turbo compressors, electrical equipment etc.

Potential fire sources are classified and marked according to factors (construction and operational parameters) that influence occurrence and development of fire (hazard). Basic hazard factors are as follows:

- type of a system and its operation outline,
- localizing fire source in a system,
- parameters and properties of flammable liquids,
- localizing fire sources in an engine room,
- geometry of system elements (inter alia, flow section),
- characteristics of typical ignition sources (inter alia, temperature, distance to the leakage source and its shape),
- characteristics of fire protection system (inter alia, liquid dispersion reduction, a number of proper fire detectors, equipment and nozzles of fire-extinguishing system).

Identification of fire sources is based on statistical data concerning real fires, i.e. frequency and causes of their occurrence. To determine the overall number of potential fire sources, a condition that the estimated and real relative fire frequencies are equal (or similar) is taken into consideration.

1. Adoption of a fire event tree

To adopt a fire event tree, the following original scenario (sequence of events) is assumed:

1. leakage of flammable liquid
2. flammable mixture and ignition source interaction
3. fire break out (ignition)
4. fire detection (detector activation)
5. preliminary fire fighting (without cutting off liquid supply)
6. power cut-off
7. full scale fire fighting (use of fixed fire-extinguishing system).

Depending on which possibility of an event has been chosen (yes or no), the original sequence is expanded as secondary events branches, the time limit of which is a fire of various scales (or no fire).

Fig. 1 presents the event tree for engine-room fires.

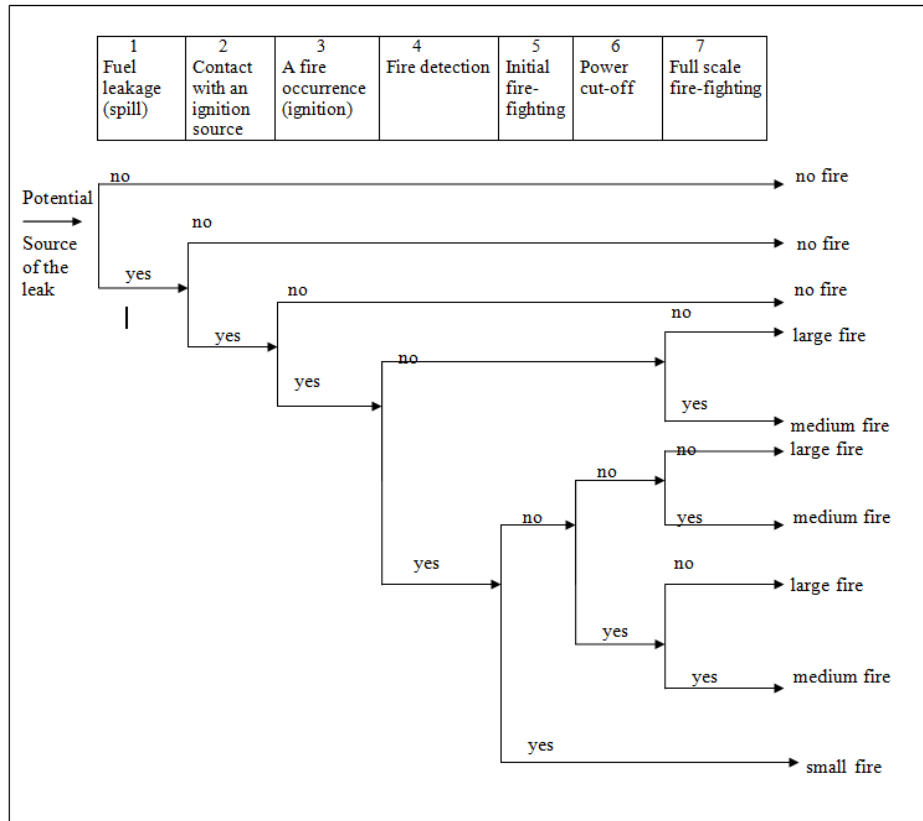

Fig. 1. Event tree for engine-room fires

3.3. Calculation of relative frequency

Frequency of flammable liquid leakages is determined on the basis of damage probability in oil systems using various data such as “Process Equipment Reliability Data” and “Ship Reliability Survey” [6]. The values used are:

Joints	4.10×10^{-3} 1/year
Valves	1.09×10^{-3} 1/year
Accessories	1.80×10^{-4} 1/year

Probability of sprayed flammable liquid (leakage) interaction with an ignition source is calculated with the following formula:

$$P_{it} = \frac{R_{\max} - \lambda}{R_{\max}} \cdot \frac{2\phi + \omega}{360} \cdot 0,5 \cdot f,$$

where:

R_{\max} – spray reach,

λ - reduced distance between a leakage point and a source of ignition,

ϕ – liquid spray cone angle in horizontal plane,

f – coefficient of splash protection,

ω - coefficient of shape (2D) projection of ignition source onto a plane perpendicular to the leakage direction,

The spray reach has been calculated with the following formula:

$$R_{\max} = \frac{V_0^2}{2g} \cdot \sin 2\theta$$

where:

V_o – liquid leakage velocity,
 2θ – spray cone angle in horizontal plane,
 g – gravitational acceleration.

Probability of ignition during an interaction between liquid splashed during leaking and the source of ignition, is calculated with the following formula:

$$P_i = p_{it} \cdot C_t,$$

where:

C_t – coefficient taking into consideration a temperature of the liquid,

p_{it} – coefficient taking into consideration the distance between a source of leakage and a source of ignition,

Probability of fire detection is calculated with the following formulas:

$$P_d = 1 - (1 - p_{det})^{n_d}, \text{ for } n_d \geq 1$$

$$P_d = p_{det} \cdot 0.5, \text{ dla } n_d = 0,$$

where:

p_{det} – coefficient of fire detection,

n_d – a number of fire detectors.

Probability of fire extinguishment with the use of proper equipment (fire-extinguisher) is calculated with the following formulas:

$$P_g = P_{gi} \cdot k$$

$$P_{gi} = 1 - [1 - \exp\{-\left(\frac{E4}{b}\right)^a\}]^{n_g}$$

where:

$E4$ – radiant heat at a distance of 4 m from the centre of a flame [$\text{kJ/m}^2 \cdot \text{h}$],

$a = 3,4$ $b = 16.33 \times 10^3$ – fixed coefficients,

n_g – a number of fire-extinguishers,

k – operator's safety coefficient.

Effective range of fire-extinguisher (4 m) and operator's safety coefficient ($k = 0.99$ – for $E4 < 1000$, $k = 0.1$ – for $E4 < 5000$) are taken into consideration for calculations.

Probability of fire extinguishment with the use of fire foam from fixed foam system nozzles is calculated with the following formula:

$$P_f = 1 - [1 - \exp\{-\left(\frac{E10}{b}\right)^a\}]^{n_d}$$

where:

$E10$ – radiant heat at a distance of 10 m from the centre of a flame,

n_d – a number of nozzles.

Fig. 2 presents a relation between radiant heat and a radius of a flame expressed with an empirical formula.

The radius of the flame 's base is calculated with the following ratio:

$$\Pi R^2 = \frac{A(0,2)^2 \cdot V_o}{V_B},$$

where:

R – radius of a flame (cylindrical),

A – section of a pipeline supplying flammable liquid,

V_o – liquid (leakage) outflow velocity,

V_B – burning velocity ($0.28 \cdot 10^{-4}$ m/s).

In a geometric model of the flame's shape, it is assumed that the leakage was a result of a crack or loose joint of a pipeline. It has been assumed that a fire of an overflow area corresponds to 20% of damage and that the amounts of leaking liquid and burning liquid are equal.

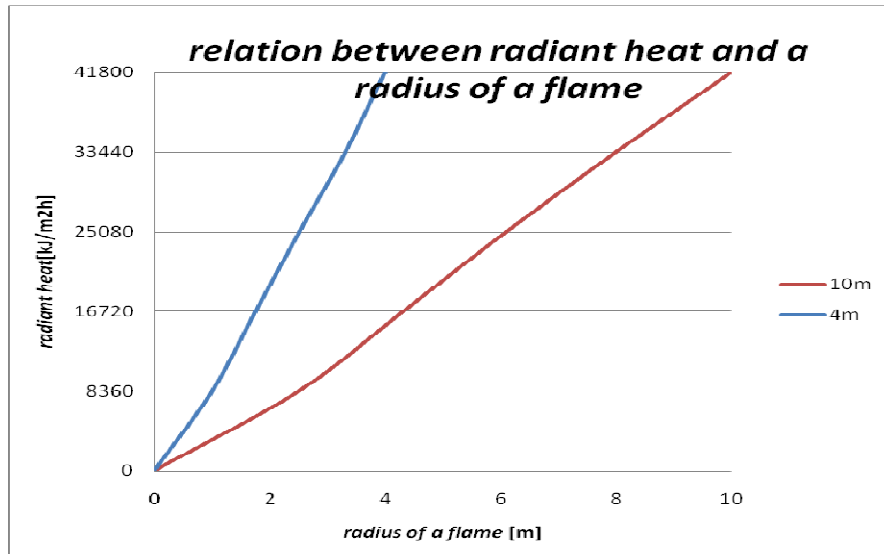

Fig. 2. The relation between radiant heat and a radius of a flame (for leakages caused by cracks or lack of tightness in joints of pipelines)

The probability of efficient initial fire extinguishing (small fire) is calculated with the following formula:

$$P_e = 1 - (1 - P_g) \cdot (1 - P_f)$$

The following values of probability of efficient large fire extinguishing (full scale) with the use of a fixed fire-extinguishing system are adopted:

$P_s = 0.99$ – after fuel cut-off,

$P_s = 0.9$ – without fuel cut-off.

The value of 0.99 for the probability of efficient fuel cut-off is adopted.

4. Fire risk control

In order to prevent or control fire accidents different countermeasures can be considered. These are: installing additional fittings, accesories and apparatuses for preventing oil leakage and ignition, for the fire detection and for fire fighting.

In the trial application numbers of safety equipment were considered as risk control measures. These were:

- number of smoke detectors (n_w),
- number of fire extinguishers (n_g),
- number of nozzles of foam extinguishing systems (n_d).

The effectiveness of the changes in numbers of safety equipment on fire hazard has been expressed by the risk sensivity factor using the following formula:

$$C_f = \frac{F_+ - F_-}{F_o} \cdot \frac{1}{n}$$

where:

F_o – relative fire frequency with the safety equipment according to the initial classification [1/ship year],

F_+ – relative fire frequency with more safety equipment,

F_- – relative fire frequency with less safety equipment,

$n = 2$,

$$n = 1 - \text{for } F. = 0.$$

The effects of number of safety equipment to scale of fire are laid down in table 1.

Table 1 Effect of number of safety equipment to scale of fire.

Risk area	Number of Safety Equipment			Small Fire		Medium Fire		Large Fire	
	n _w	n _g	n _d	F _o 1/ship year	C _f	F _o 1/ship year	C _f	F _o 1/ship year	C _f
Power generat Sets platform	3	3	2	2.81x10 ⁻⁴	-	2.26x10 ⁻⁵	-	4.70 x 10 ⁻²	-
	3	3	2+1		2.43x10 ⁻²		-3.67x10 ⁻²		2.43x10 ⁻²
	3	3+1	2		8.35x10 ⁻⁵		-1.23x10 ⁻⁴		8.02x10 ⁻⁵
	3+1	3	2		2.53x10 ⁻²		-3.72x10 ⁻²		2.39x10 ⁻²
Boiler platform	1	2	3	8.75x10 ⁻⁶	-	1.98x10 ⁻⁶	-	2,19x10 ⁻⁷	-
	1	2	3+1		5.88x10 ⁻⁵		-8.65x10 ⁻⁵		-5.65x10 ⁻⁵
	1	2+1	3		1.16x10 ⁻²		-1.71x10 ⁻⁷		-1.12x10 ⁻⁷
	1+1	2	3		5.88x10 ⁻⁵		-8.65x10 ⁻⁵		-5.65x10 ⁻⁵

Note:

F_o – relative fire frequency for the initial amount of safety equipment (n_w, n_g, n_d),

C_f – risk sensitivity factor (for increase by 1 in n_w, n_g and n_d).

According to the table, a greater number of fire-extinguishers, detectors and nozzles causes an increase of probability of small fires and at the same time decreases probability of medium and large fires. The impact of the number of fire-extinguishers on risk sensitivity is much lower than that of the number of detectors and nozzles. Absolute value of the sensitivity coefficient is greater for areas of higher risk.

5. Conclusions

The formal fire risk assessment described in this paper is based on a probabilistic model. Its preliminary assumptions and initial parameters for fire frequency calculations are adopted on the basis of statistical data for real fires. With the use of the model, it is possible to calculate relative frequencies of fires of a various scale for individual fire sources in fuel oil and diesel oil systems as well as to calculate total fire hazard for machines and spaces, and their contribution to general hazard concerning engine rooms.

The accuracy of fire frequencies calculations is approximate and when applied to quantitative assessment of hazard the credibility of results is limited. The fundamental simplification of the model is that the influence of human factor is not taken into consideration.

For the purposes of searching for possibilities of construction influence on fire hazard, qualitative assessment is sufficient. It is so-called sensitivity analysis that is based on relative fire frequency calculations for various types of protection (e.g. with the use of liquid splash protection, various number of fire detectors and fire extinguishing nozzles).

In this respect, the model described in this paper has been used to verify requirements for flammable oil systems in ship engine-rooms. It may be assumed that creating an adequate calculation model for the purpose of a general fire hazard analysis of an engine-room is a significant challenge.

References

1. Charchalis A., Czyż S.: Analysis of fire hazard and safety requirements of a sea vessel engine rooms, *Jurnal of Kones* 2011
2. Charchalis A., Czyż S.: Analysis method of fire hazard of fuel oil and diesel oil systems in sea vessels engine rooms, *Jurnal of Kones* 2011
3. Charchalis A., Czyż S.: Trial application of the formal fire risk assessment to fire prevention in ship engine rooms, *Jurnal of Konbin* no.2, 2011
4. Guidelines for Measures to Prevent Fires in Engine-Rooms and Cargo-Pump Rooms. IMO MSC.1/Circ 1321, London 2009
5. Liddiard E: Failures of low pressure fuel systems on ship's diesel engines MAIB MSA Research Project, London 1992.
6. Results of the research applicability of Formal Safety Assessment to Comprehensive Review SOLAS Chapter I-2, IMO FP 44/Inf., London 1999.



Województwo
Zachodniopomorskie

The paper was published by financial supporting of
West Pomeranian Province

